



Stoginiai ventilatoriai

Roof fans

Dachventilatoren

Крышные вентиляторы



Stoginiai ventilatoriai, skirti oro ištraukimui. Nenaudojami užteršto oro, agresyvių, sprogių dujų transportavimui.

Sparnuotė: atgal lenktas sparneliais, plastmasinė/cinkuoto plieno.

Variklis: išorinis rotorius, integruota termokontaktinė variklio apsauga, ilgai tarnaujantys nereikalaujantys priežiūros guoliai.

Korpusas: dažytas RAL 9005.



Dachventilatoren, für Abluft bestimmt. Nicht geeignet für die Beförderung von verschmutzter Luft, aggressiven, explosiven Gasen.

Laufblad ist rückwärts gekrümmt, aus Kunststoff oder verzinktem Stahl.

Der Motor: Außenrotor, integrierter Thermokontakt-Motorschutz, dauerhafte, keine Pflege erfordernde Lager.

Das Gehäuse: RAL 9005, gestrichen.



Roof fans with horizontal discharge are used to extract air from different premises. Easy access to clean an impeller. Not suitable for polluted air, aggressive and explosive gases.

Impeller with backward curved blades made of galvanized steel.

Motor: external rotor, motor protection built-in thermal-contact, free-maintenance ball bearings.

Housing: powder coated painting RAL 9005.



Крышные вентиляторы для вытяжки воздуха. Не используются при транспортировке загрязнённого воздуха, агрессивных, взрывоопасных газов.

Крыльчатка: загнутые назад лопадки, пластмасса/оцинкованная сталь.

Двигатель: наружный ротор, встроенная термодатная защита двигателя, не требующие ухода подшипники с длительным сроком службы.

Корпус: окрашенный RAL 9005.

#### Accessories



KSV  
p. 194



TGRV  
p. 153



MTY  
p. 156

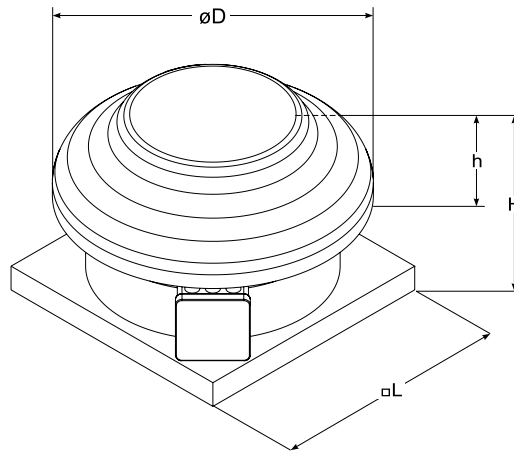

Type	Dimensions [mm]			
	$\varnothing D$	H	h	$\square L$
VSA 175 M	344	227	107	305
VSA 190 L	344	227	107	305
VSA 220 S	450	234	109	405
VSA 220 M	450	234	109	405
VSA 225 L	450	247	109	405
VSA 250 L	450	247	109	405

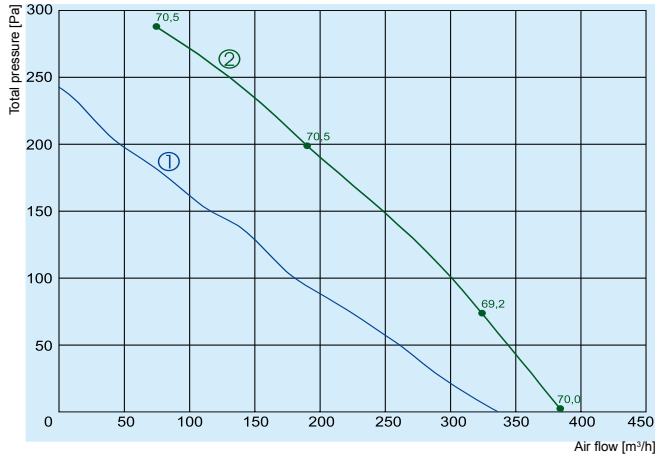

① **VSA 175 M**  
 ② **VSA 190 L**

		<b>VSA 175 M</b>	<b>VSA 190 L</b>
Voltage/Frequency	[V/Hz]	230/50	230/50
Power consumption	[W]	53	63
Current	[A]	0,33	0,27
Speed	[min <sup>-1</sup> ]	2350	2449
Max. airflow	[m <sup>3</sup> /h]	336	386
Max. air temperature	[°C]	40	50
Speed controller		TGRV1,5 / MTY0	TGRV1,5 / MTY0
Weight	[kg]	4,0	4,4
Wiring diagram		No. 1	No. 2
Protection class:	motor	IP-44	IP-44
	terminal box	IP-54	IP-54

**175 M**

	L <sub>pa</sub> dB(A)	L <sub>wa</sub> total dB(A)	L <sub>wa</sub> , dB(A)								
			100 Hz	125 Hz	250 Hz	500 Hz	1 kHz	2,5 kHz	5 kHz	8 kHz	16 kHz
Inlet	50	60	50	46	63	49	42	48	35	26	19
5 mic. at 1,3 m dist.	64	74	63	60	70	63	60	62	45	38	32

 Measured at 337 m<sup>3</sup>/h, 0 Pa

**190 L**

	L <sub>pa</sub> dB(A)	L <sub>wa</sub> total dB(A)	L <sub>wa</sub> , dB(A)								
			63 Hz	125 Hz	250 Hz	500 Hz	1 kHz	2 kHz	4 kHz	8 kHz	16 kHz
Inlet	59	66	38	44	54	59	60	61	57	41	28
Outlet at 1 m dist.	61	68	35	44	59	62	65	60	55	39	26

 Measured at 270 m<sup>3</sup>/h, 134 Pa

The fan characteristic curves were determined in accordance with DIN 24163 resp. ISO 5801. The sound power levels were determined in accordance with DIN 45635 resp. ISO 3744 at a distance of 1 m from the fan

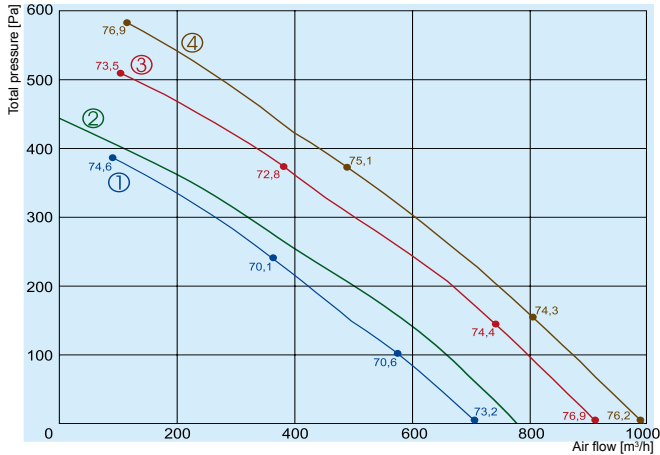

- ① VSA 220 S
- ② VSA 220 M
- ③ VSA 225 L
- ④ VSA 250 L

		VSA 220 S	VSA 220 M	VSA 225 L	VSA 250 L
Voltage/Frequency	[V/Hz]	230/50	230/50	230/50	230/50
Power consumption	[W]	99	85	160	219
Current	[A]	0,43	0,38	0,71	0,95
Speed	[min <sup>-1</sup> ]	2630	2700	2604	2504
Max. airflow	[m³/h]	711	770	915	993
Max. air temperature	[°C]	40	55	60	40
Speed controller		TGRV1,5 /MTY 0	TGRV1,5 /MTY 0	TGRV1,5/MTY1	TGRV1,5/MTY1
Weight	[kg]	6,6	7,0	7,8	7,9
Wiring diagram		No. 2	No. 1	No. 2	No. 2
Protection class:	motor	IP-44	IP-44	IP-44	IP-44
	terminal box	IP-54	IP-54	IP-54	IP-54

### 220 S

	L <sub>pa</sub> dB(A)	L <sub>wa</sub> total dB(A)	L <sub>wa</sub> , dB(A)								
			63 Hz	125 Hz	250 Hz	500 Hz	1 kHz	2 kHz	4 kHz	8 kHz	16 kHz
Inlet	62	69	40	52	56	63	64	62	56	51	33
Outlet at 1 m dist.	63	70	38	53	60	64	65	61	56	46	30

Measured at 428 m³/h, 197 Pa

### 220 M

	L <sub>pa</sub> dB(A)	L <sub>wa</sub> total dB(A)	L <sub>wa</sub> , dB(A)								
			100 Hz	125 Hz	250 Hz	500 Hz	1 kHz	2,5 kHz	5 kHz	8 kHz	16 kHz
Inlet	58	68	77	80	80	78	75	73	69	59	50
5 mic. at 1,3 m dist.	70	80	71	68	72	69	70	67	65	54	48

Measured at 770 m³/h, 0 Pa

### 225 L

	L <sub>pa</sub> dB(A)	L <sub>wa</sub> total dB(A)	L <sub>wa</sub> , dB(A)								
			63 Hz	125 Hz	250 Hz	500 Hz	1 kHz	2 kHz	4 kHz	8 kHz	16 kHz
Inlet	62	69	41	52	57	63	64	61	60	53	40
Outlet at 1 m dist.	65	72	40	53	61	66	67	66	60	50	37

Measured at 454 m³/h, 323 Pa

### 250 L

	L <sub>pa</sub> dB(A)	L <sub>wa</sub> total dB(A)	L <sub>wa</sub> , dB(A)								
			63 Hz	125 Hz	250 Hz	500 Hz	1 kHz	2 kHz	4 kHz	8 kHz	16 kHz
Inlet	64	71	44	57	59	64	65	63	62	57	44
Outlet at 1 m dist.	66	73	42	58	63	66	69	67	60	53	41

Measured at 711 m³/h, 227 Pa

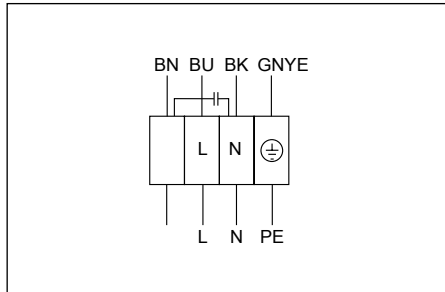

**Wiring diagram No. 1 (1~230V)**

**GNYE** - green-yellow / grün-gelb  
**BK** - black / schwarz  
**BU** - blue / blau  
**BN** - brown / braun

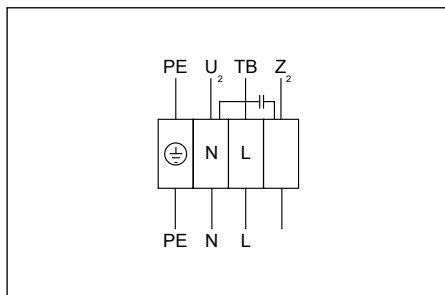

**Wiring diagram No. 2 (1~230V)**

**U<sub>2</sub>** - blue or grey  
**Z<sub>2</sub>** - black  
**TB** - braun